

'PUSH CONTROL' CONCEALED THERMOSTATIC SHOWER VALVES (1, 2 & 3 OUTLET MODELS)

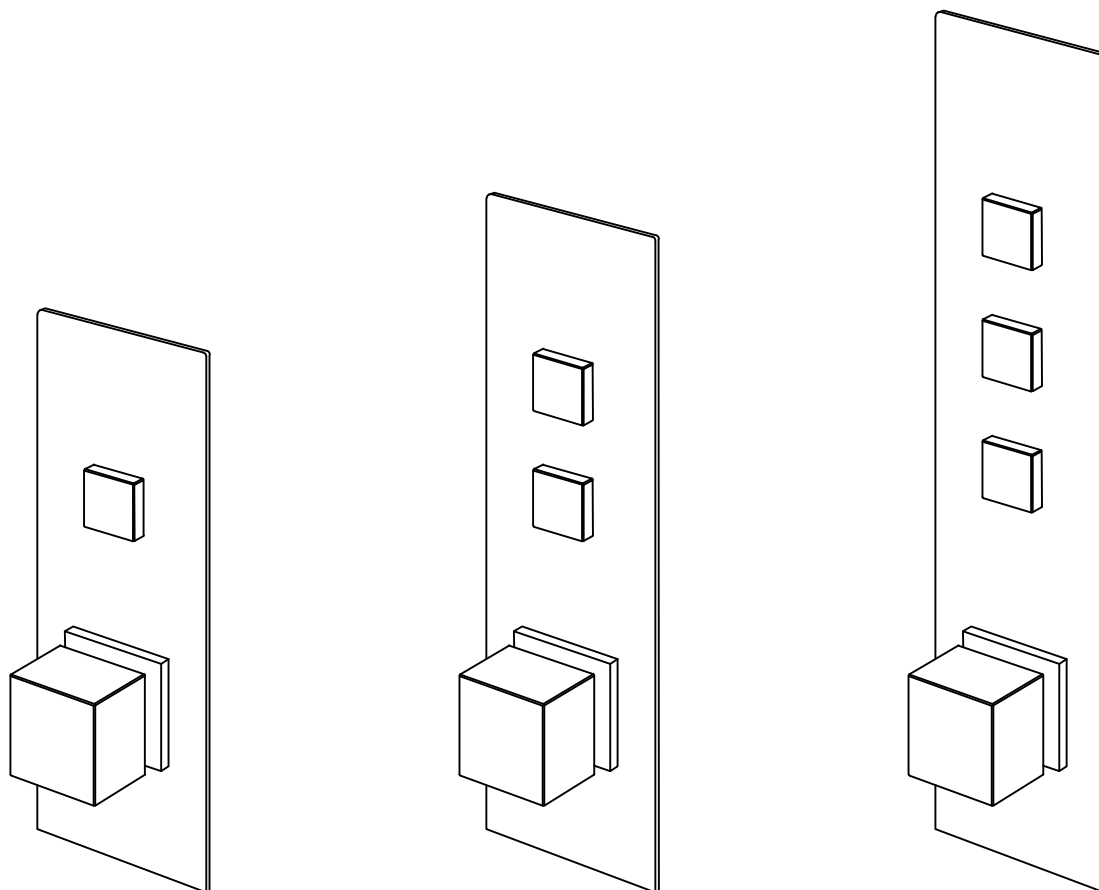

Important information (Please leave this installation & user guide with the end user)

This installation guide is for all the 'Push Control' Thermostatic shower valves. It covers the installation and operation of the Shower Valves.

All 'Push Control' concealed models are thermostatically controlled using a Valquest patented cartridge.

They have been designed to provide a flow of water at a safe temperature when installed as described in this manual. The valves are suitable for use on pressure from as low as 1 bar.

To activate the shower, a simple press of the Push Button Flow Control (PBFC) starts or stops the flow of water from the shower outlet.

Depending on your chosen model, the PBFC's work independently of each other. So, if your chosen model has multi PBFC's, they can be used individually, or you can enjoy up to two shower outlets together (dependant upon on your water pressure - see flow rate data).

The valves are also suitable, without modification, for all types of installation, including pumped*, gravity systems, mains pressure and combination boilers.

*There are lots of choices with shower pumps, including positive or negative head pumps - Please ask your installer to confirm which will be suitable for your specific installation.

Safety

We recommend that this product is fitted by a fully qualified installer. The installation must comply with all current water regulations. Please note: This valve **MUST** be commissioned during installation to suit site conditions. In order for this product to operate as designed it must be installed and commissioned as stated in this manual.

Components List - 2 Outlet Model:

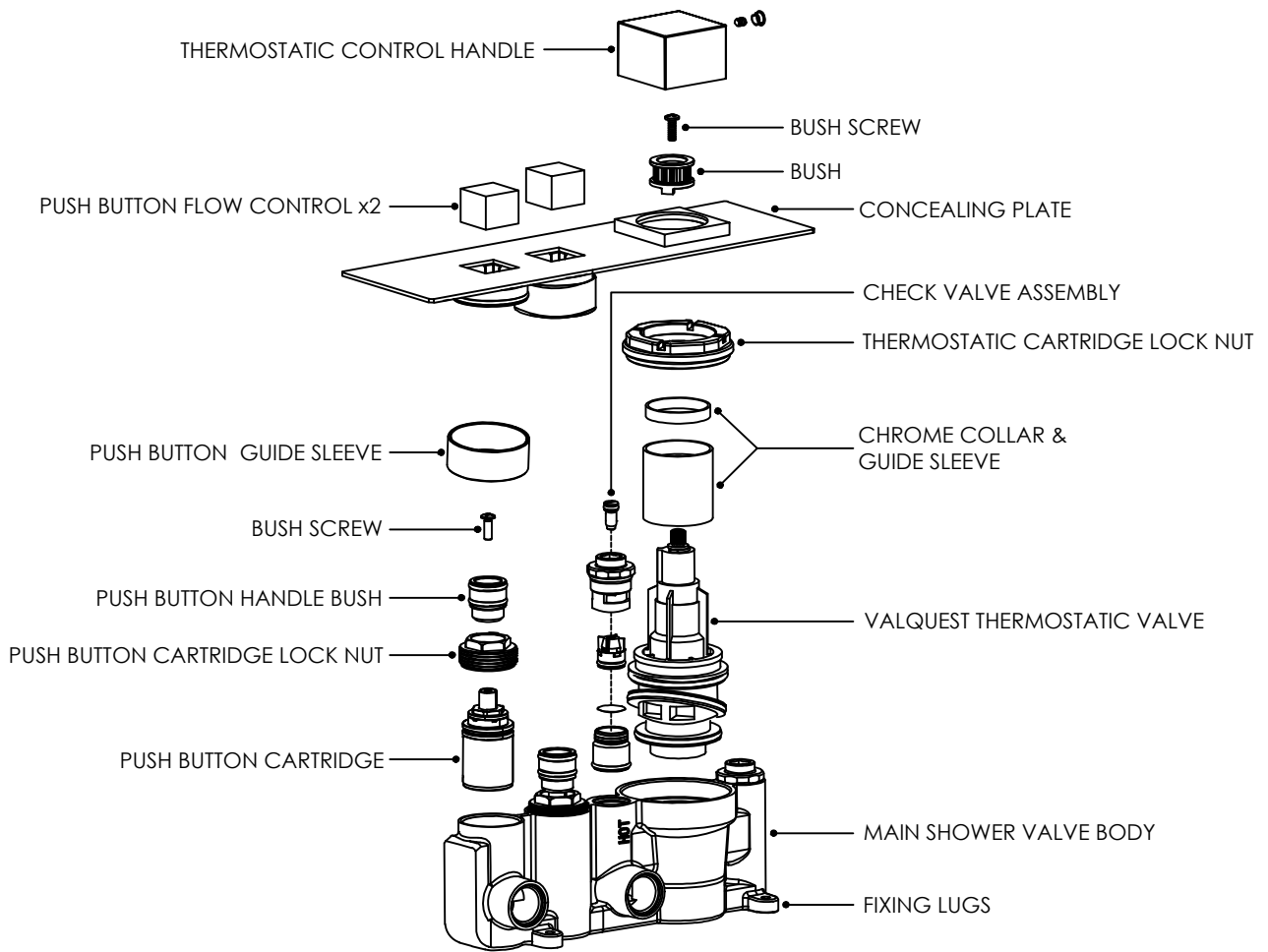

Key Dimensions:

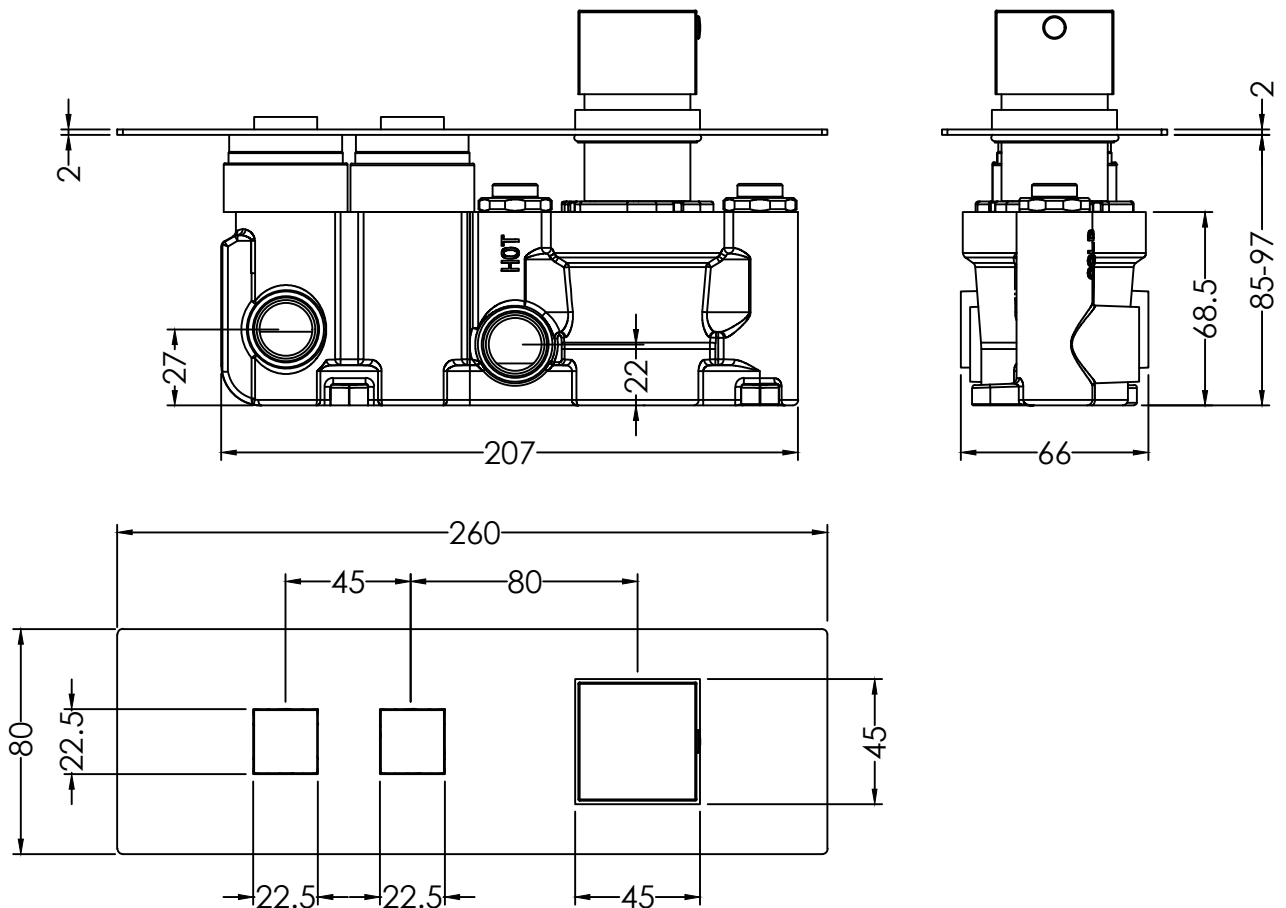

Components List - 3 Outlet Model:

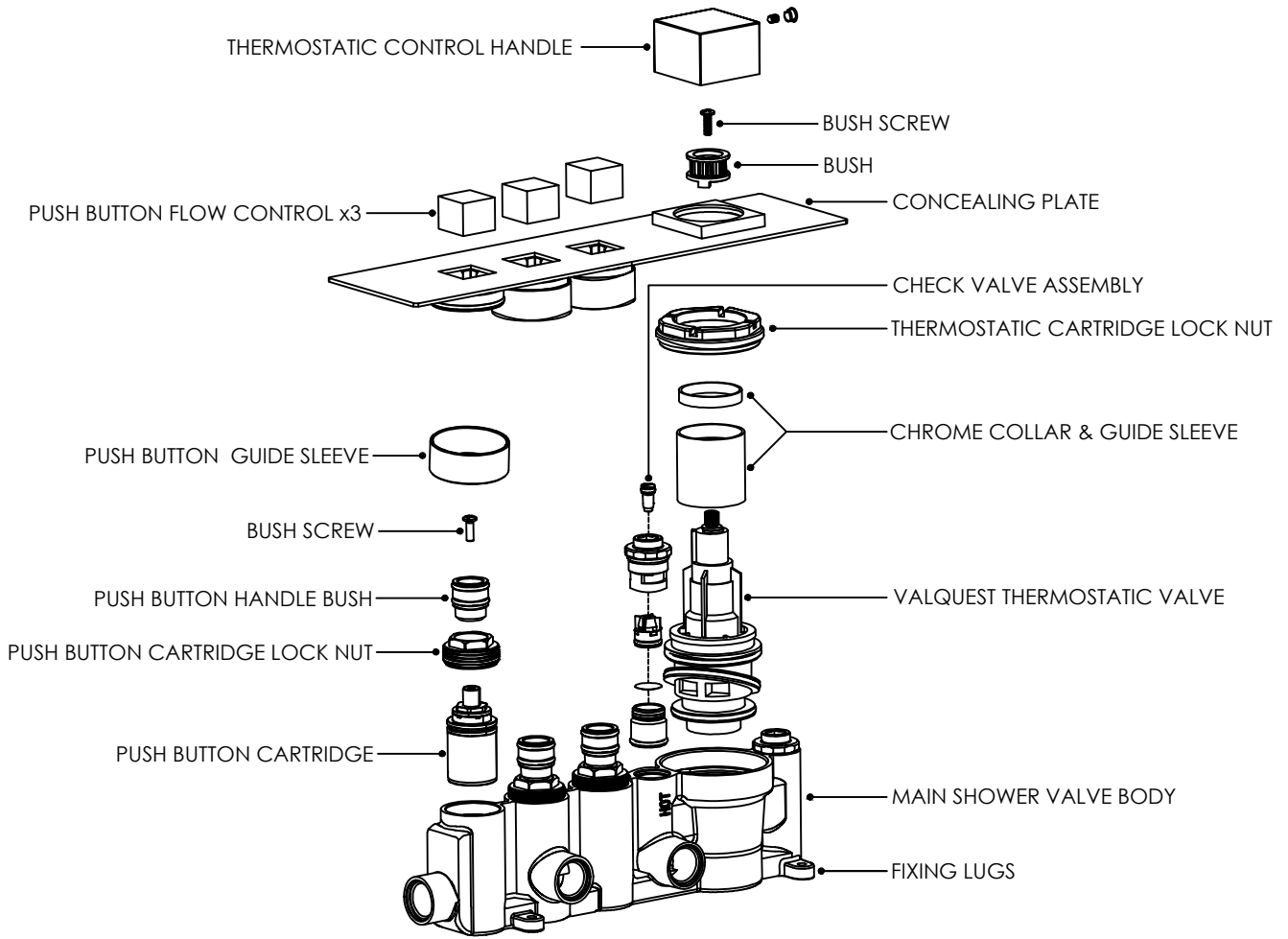

Key Dimensions:

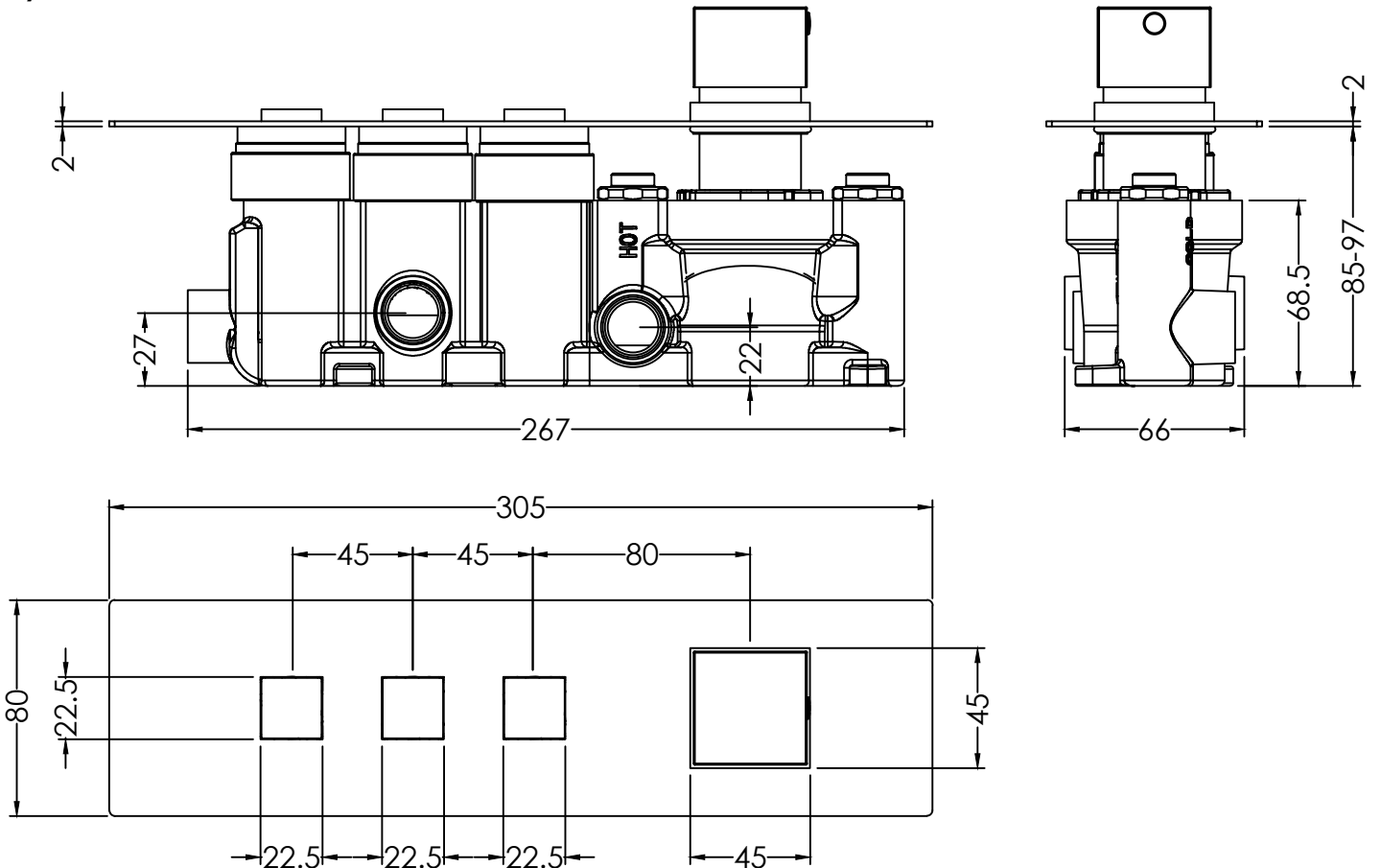

Technical Data

Min operating pressure: 1 bar

Max operating Pressure: 5 bar

Factory Outlet Temperature Setting:

Minimum Temperature Differential (Mixed water to hot water): 10°C Temperature Stability: ±2°C

FLOW RATE DATA						
1 OUTLET MODEL	BAR	1	2	3	4	5
	Ltr/min	11.1	16.1	19.7	22.8	25.2
2 OUTLET MODEL	BAR	1	2	3	4	5
1 OUTLET	Ltr/min	8.9	13.6	16.7	19.4	21.7
2 OUTLET COMBINED	Ltr/min	12.4	19.7	24.9	29.0	32.6
3 OUTLET MODEL	BAR	1	2	3	4	5
1 OUTLET	Ltr/min	8.1	12.6	15.6	18.0	20.2
2 OUTLET COMBINED	Ltr/min	12.0	19.5	24.5	28.5	32.0
3 OUTLET COMBINED	Ltr/min	13.8	21.8	28.0	32.9	37.0

Operation

To activate the shower, a simple press of the PBFC starts or stops the flow of water from the shower outlet. To control the temperature, turn the temperature control handle clockwise to reduce the water temperature, and turn anti-clockwise to increase the water temperature.

Installation

All Valves:

The hot inlet of the valve must always be connected to the hot pipework. The hot inlet of the valve is clearly marked. Failure to follow this instruction will mean the valve will not operate correctly.

Cartridge Reversal:

Please note that the pipe work on site should be plumbed with the hot on the left and the cold on the right as you look at it. If this is not the case, instead of turning the valve body around to match the pipe work, the cartridge can be taken out of the valve body, turned 180° and placed back in the valve body. The Hot & Cold inlets will now match the incoming water.

When removing the cartridge, please undo the retaining nut and then pull gently on the cartridge. There may be some residual water behind the cartridge. Remove the cartridge from the valve body and turn it 180° so that the positional lug on the cartridge lines up with the slot in the valve body. Push the cartridge into the valve body making sure the lug is in the slot. Replace the retaining nut being careful not to over tighten.

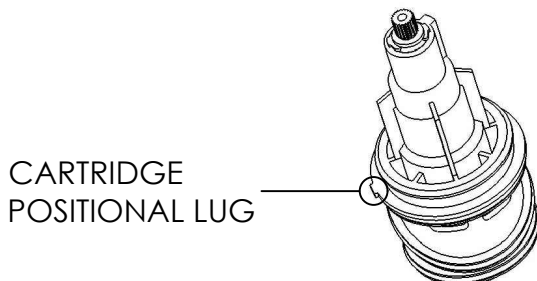

NB There is some in-wall depth adjustment on this shower valve to assist with installation. This needs to be planned before installation commences. See basic valve dimensions for guidance.

1. Remove the chrome collar and guide sleeve from the shower valve body, and leave to one side in a safe place.
2. You must install accessible isolation valves in the HOT & COLD water supply lines for servicing purposes.
3. The plumbing connections on the inlets & outlet are all ½" BSP female threads.
4. Determine the fixing position and make a suitable recess in the wall to house the valve body. NB This space should leave enough access to be able to service the valve body and all its connection points after the concealing plate is removed. In order for the push-button(s) to operate freely, the valve body must be set parallel to the concealing plate when set into the wall.
5. Secure the shower valve body in position to a suitable fixing point, using the fixing lugs that are cast into the base of the body.
6. Now the shower valve body is securely mounted in the wall recess, make sure the pipe work is thoroughly flushed through to remove any debris from the system before connecting the water supplies to the valve body. NB Failure to do this could invalidate the guarantee.
7. The plumbing connections should then be made to the HOT & COLD water inlets (which are clearly marked). If for some reason the pipe work feeds on site are the wrong way around, the cartridge can be taken out of the valve body, turned 180° and placed back in the valve body. See cartridge reversal instruction for guidance on this.
8. Make the plumbing connection(s) to the water outlet. This will take the water to the chosen auxiliary product (shower kit) you have selected to run with this shower.
9. Turn on the water supply and check for leaks.
10. Check the maximum water temperature from the terminal fitting with a thermometer. The recommended maximum terminal outlet temperature is 43°C.
11. The valve can now be commissioned.
12. Re-fit the chrome collar & guide sleeve to the valve body.
13. Remove the push button guide sleeve from the back of the concealing plate and securely screw this onto the push button cartridge lock nut.
14. Push the concealing plate over the controls, applying a small bead of silicone behind the concealing plate to create a water tight seal so that water cannot ingress into the wall cavity.
15. Fit the push button flow control over the push button handle bush and press into position making sure it goes over the two "O" rings for a snug fit.
16. Fit the thermostatic control handle.
17. Your shower valve is now ready for use.

Temperature Adjustment

1. Remove the handle on the thermostat control. The method will differ depending on the handle type. The spline/Brass stop Ring will now be exposed.
2. If a Brass Stop Ring is in place, please remove it. Press one of the push button flow controls to activate the flow.
3. If the shower is too cold then turn the spline anti-clockwise. If the shower is too hot then turn the spline clockwise. Let the water temperature stabilise after every adjustment. We recommend a max temperature of 43°C.
4. When the temperature is correct, press the push button flow control again to stop the water flow. Do not move the spline again until after the handle is secured in place. The max temperature is now set and any movement of the spline will alter the temperature.
5. The handle can now be put back in place. When the handle is being placed over the spline, please ensure that the handle Stop Lug is against the cartridge Stop Lug preventing the handle from being turned any further anti clockwise. This prevents the shower valve from reaching a temperature that is higher than the set point.
Depending on your handle type the temperature will be limited by a handle with an in build stop lug or by a separate Brass Stop Ring. Please see the diagrams below.
6. The handle can now be fixed in place. The shower should have a safe maximum showering temperature.

Cartridge Stop Lug

The handle stop lug should be against this face at the maximum temperature setting. This stops further anti-clockwise movement

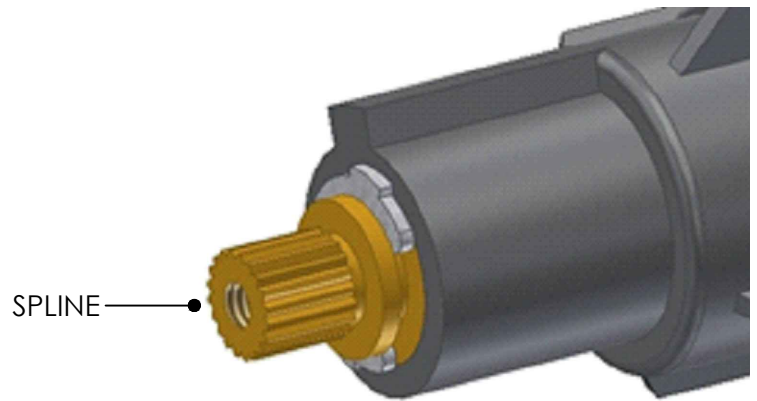

Brass Stop Ring

Some handle types have a brass stop ring which is placed over the spline and limits the anti-clockwise movement of the handle.



Aftercare

- When cleaning the valve please do not use a substance that could possibly damage the surface finish. We recommend that soapy water with a mild detergent is used.
- Please take care not to damage the surface finish of the valve. The finish is polished chrome and can be easily marked.

Diagnostics

Symptoms	Possible Cause	Action Required
1. The showering water temperature is too hot.	1.1 Temperature set point incorrectly commissioned.	1.1.1 Please see temperature adjustment section.
	1.2 Not enough cold water getting to the valve.	1.2.1 Please see temperature adjustment section.
		1.2.2 Check for blockage in supply pipes.
		1.2.3 Check for blockage in check valve filters.
1.3 Ambient cold water temperature has increased.	1.3.1 Re position the temperature control handle - see temperature adjustment section.	
2. The showering water temperature is too cold.	2.1 Temperature set point incorrectly commissioned.	2.1.1 Please see temperature adjustment section.
	2.2 Not enough hot water getting to the valve.	2.2.1 Please see temperature adjustment section.
		2.2.2 Check for blockage in supply pipes.
		2.2.3 Check for blockage in check valve filters.
	2.3 Ambient cold water temperature has decreased.	2.3.1 Re position the temperature control handle - see temperature adjustment section.
	2.4 Operating conditions are incorrect.	2.4.1. See Technical data for correct operating pressures.
2.5 Hot water supply temperature not hot enough.	2.5.1 Check that the hot water temperature at a basin tap is acceptable, which should be around 55-60 deg. If it isn't, make sure the heating appliance is adjusted to increase the hot supply temperature.	
	2.5.2 Make sure the heating appliance has sufficient hot water storage capacity.	
3. Water is not mixing correctly, or shower temperature is varying.	3.1 Hot and cold water supplies are plumbed to the wrong side of the valve body.	3.1.1 Remove the Valquest thermostatic cartridge, turn 180 degrees and replace.
4. Low or no water flow from shower (single and multi-outlet showers).	4.1 Possible blockage in the system.	4.1.1 Check & clean any filters as necessary.
		4.1.2 Supply pipe work may be blocked. Consult a qualified installer.
		4.1.3 Make sure any in line service isolator valves are in the fully open position.
	4.2 Operating conditions are incorrect.	4.2.1 See Technical data for correct operating pressures.
	4.3 Valve is obstructed by debris.	4.3.1 Clean check valves.
	4.4 Valve anti-scald has activated due to operating conditions.	4.4.1 See Technical data for correct operating pressures and inlet water supply temperatures.
	4.5 Water supplies have been cut off.	4.5.1 Check other water outlets elsewhere in the house, and contact water authority if necessary.
	4.6 Shower outlet may be blocked (handset, shower head etc).	4.6.1 Clean the shower outlet.
4.7 Multiple shower outlets are not getting enough water.		4.7.1 Make sure your system is capable of delivering the required volume of water.
	4.7.2 Make sure any in line service isolator valves are in the fully open position.	
5. Leak when shower valve in "off" position.	5.1 Check that the leak is from the shower valve and not residual of water in the shower head / handset.	5.1.1 Remove the shower head / handset from its' feed to see if any water is dripping from the flexible hose or shower arm. If this is not leaking you are experiencing residual water in the shower fitting which is not a fault.
		5.1.2 If the leak is from the shower valve, a new flow control cartridge is required.
6. Fluctuating flow rate.	6.1 Possible blockage in the system.	6.1.1 Check & clean any filters as necessary.
		6.1.2 Make sure any in line service isolator valves are in the fully open position.
		6.1.3 Supply pipe work may be blocked. Consult a qualified installer.
	6.2 Operating conditions are incorrect.	6.2.1 See Technical data for correct operating pressures.
	6.3 Dynamic inlet pressures are not balanced.	6.3.1 Consult a qualified installer.