

# Quick start guide

**maia**<sup>®</sup>  
innovation in worksurface technology

## PREPARATION

The work surfaces and additional materials must be conditioned for at least 24 hours at room temperature prior to fitting.

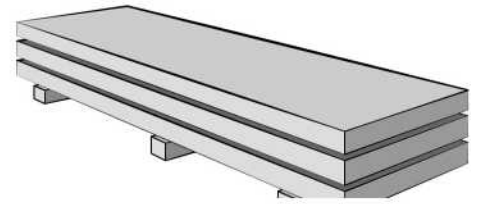

**Must not be stored vertical and on one edge**

## CHECKS

- Enough jointing kits or adhesives for the installation? 1 jointing kit per joint
- All surfaces should be checked for any damage and colour consistency prior to installation. If you are unsure of the colour consistency, sand a small patch of each of the adjoining boards to test this to ensure a satisfactory match before any installation is carried out. Ensure you are in a suitably lit environment, wipe the dust away and use a damp cloth to help get a true colour comparison

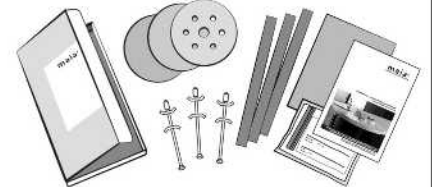

## TOOLS

- 2 ½ HP, 1850 watt router *plus*
- 3mm grooving cutter with 13mm depth cut e.g. Titman UG3 groover with UGALR arbor or Trend SP-QUAD/18, BB224 on a 33/30 x 1/2" Arbor.
- Masons mitre Jig with 30mm guide ring and 12mm twin flute TCT cutter.
- Random orbital sander for finishing.

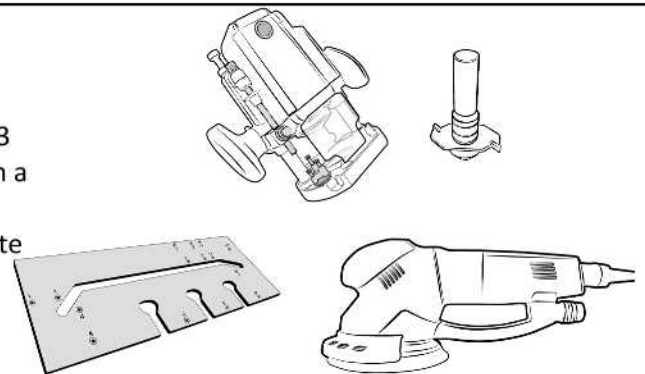

## PROCESS

- Always dry fit the worktops before bonding
- Make sure the joint is thoroughly clean using the isopropyl alcohol wipes supplied in the jointing kit
- Use of the tongues in joints is imperative and should not be missed.
- Use two layers of masking tape approximately 2mm either side of the joint. Lightly scrape off the excess adhesive but make sure a good bead is left as the adhesive shrinks very slightly as it cures.
- Mix the adhesive thoroughly in the bag. Remove the grey strip and mix the two parts together for around 1 minute or use the grey strip to run the mixture 20 times from one end of the bag to the other.
- You don't need to sand the whole of the worktop. The worksurfaces are supplied with a final matt finish and do not require any further surface finishing apart from areas that require joints and any cut ends or edges
- When planting on edging, align it to the bottom edge of the worktop.
- Leave a red abrasive pad with the householder to use in the regular care of the surface.
- All aspects of the installation of maia are also covered in a DVD that is available to view online at:

[www.maiaworksurfaces.co.uk](http://www.maiaworksurfaces.co.uk)

Over a short period of time in use in the home, maia worktops will develop a smoother finish and appearance. In the first days after installation the dry finish of the surface may show finger marks more readily than it will do when it has achieved this patina.

Regular cleaning with warm soapy water is the usual first step to remove surface marks. If grease marks remain, the gentle abrasive of Cif cream cleaner will remove most marks without harming the surface at all. This sort of cleaning has a positive effect on maia. For very stubborn grease marks or burnt on areas of fat splashes for instance, Fairy Power Spray will cut through this very easily.

It is possible to enhance the surface lustre by using Countertop Cleaner\*; as with any treatment of this nature, the application has to be repeated in order to maintain the same finish across all areas of the kitchen.

## Initial treatment and cleaning

First ensure that your maia worksurface is thoroughly cleaned with warm soapy water or Fairy Power Spray to remove any greasy residues. A mild abrasive cream cleaner such as Cif cream is also a good part of your regular maintenance regime.

Countertop Cleaner\* is designed to give a lustre to solid surface worktops – this will be particularly noticeable on darker décors. It will also help to build up the natural patina of your surface and a protective layer that will repel dirt and liquids.

Use daily when your maia worktops are first installed, after the first week this can then be reduced to a weekly application. Apply the cleaner using the microfibre cloth\* and buff to leave a streak free finish.

Countertop Cleaner\* will not remove scuffs or scratches but can mask the effect. Cover the affected area with a liberal amount of soapy water.

## WHENEVER TRYING TO REMOVE MARKS OR SCRATCHES ALWAYS TRY THE LEAST SEVERE METHOD FIRST.

### Removal of fine scuffs and scratches using the grey abrasive pad

Cover the affected area with a liberal amount of soapy water. Place the red abrasive pad onto the wet surface.

Using the foam sanding block, rub over the affected area in a circular motion. A slight paste will be generated that aids the scouring process and helps to maintain the original level of surface finish.

Finally go over the area with a mild abrasive cleaner (Cif cream), dry the area and then apply Countertop Cleaner\* as above. If marks are still evident, repeat the red abrasive pad process or, in the case of deeper scratches, move onto the use of the sanding discs.

### Removal of deeper scratches using the sanding discs

Ensure that the surface is clean and dry before starting. Place the sanding disc onto the sanding block ensuring that it is located correctly and wrapped onto both sides of the block. Always use the least severe method first.

Using small circular movements, work a small area around the affected part of the surface. A small amount of dust will be generated – this will need to be wiped off to check progress.

When the mark has been removed you will then need to use the red abrasive pad to return the surface to the original finish. Cover the same area that has been sanded plus a slightly wider area to blend in.



items marked with \* are included as part of the maia Care Kit available from retailers or at [www.maiaworksurfaces.co.uk](http://www.maiaworksurfaces.co.uk)